

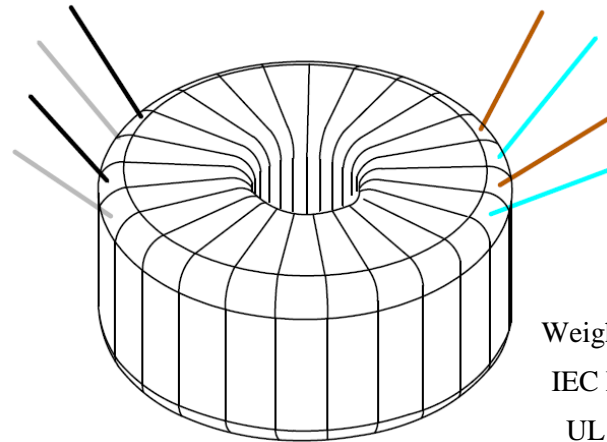

The 1000VA industrial toroidal power transformer offers higher efficiency than EI transformers, typically ranging up to 97%. Due to its effective containment of magnetic flux within the core, it significantly reduces interference with nearby components. Additionally, it generates a lot less mechanical humming and heat.

The AU series transformers are specifically designed to operate with standard 240V and 480V 60Hz power source. They feature heavier gauge copper wires than standard requirements to minimize wire loss at full power output. The dielectric leakage current test withstands up to 3500Vac between the primary and secondary coils.

This transformer includes base plate, two rubber pads, a holding disk, and a center bolt assembly.

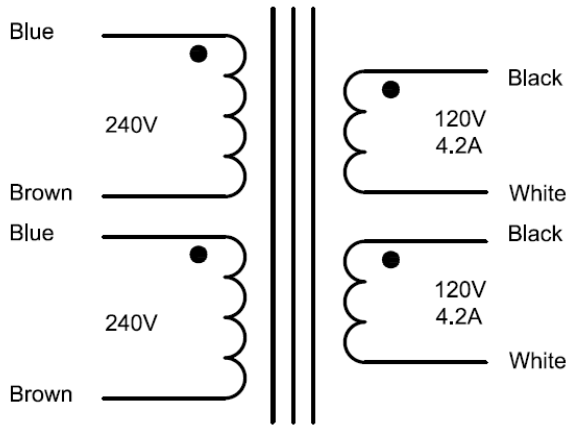

<b>Open Circuit Test (core loss test):</b> TEST CONDITION: Apply variable voltage to primary wires (0-240V tap). Set voltages 240 and 280VAC at 60Hz. No load on secondary coils. Measure the primary current and input power.	V <sub>oltage input</sub>	C <sub>urrent input</sub>	P <sub>ower lost</sub>
	240V 280V	.039A .063A	7.4W 11.2W
<b>Short Circuit Test (copper loss test):</b> TEST CONDITION: Short all secondary coils, and apply variable voltage to (parallel) primary coils. Vary the voltage from 0-20VAC at 60Hz and freeze the voltage at rated primary current.	V <sub>oltage input</sub>	C <sub>urrent rated</sub>	P <sub>ower lost</sub>
	4.02V	8.33A	33.5W
<b>Load Test (operation test):</b> TEST CONDITION: Apply 240VAC, 60Hz to the primary coils (0-240V). Connect Output 1 and Output 2 in parallel to the load. Measure the voltage and current at different load levels. The total internal impedance of the transformer can be determined as $\Delta V/\Delta I$ .	V <sub>oltage output</sub>	C <sub>urrent output</sub>	P <sub>ower output</sub>
	120.9V 119.6V	0.0A 2.39A	0W 285W
<b>DC Resistant Test:</b> DC Milli-Ohm Meter: Test primary (0-240V) and secondary coils (value for each coil).	Primary		Secondary
	1.8 ohm		0.51 ohm